

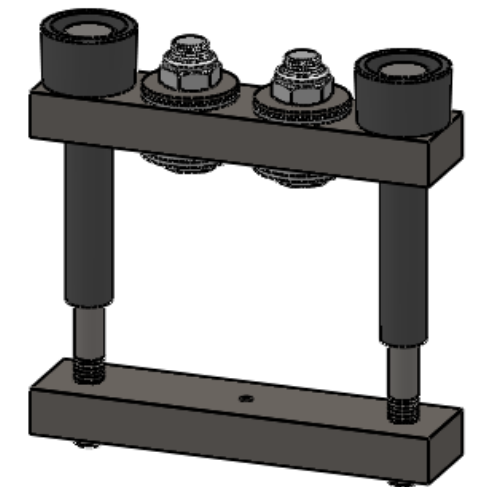

REVISION TABLE			
REV	DESCRIPTION	DRAWN	DATE
1			
2			

Item No.	Part Number	DESCRIPTION	QUANTITY
1	Bolt	M8 x 110 mm	2
2	Insulator	M8 x 61 mm	2

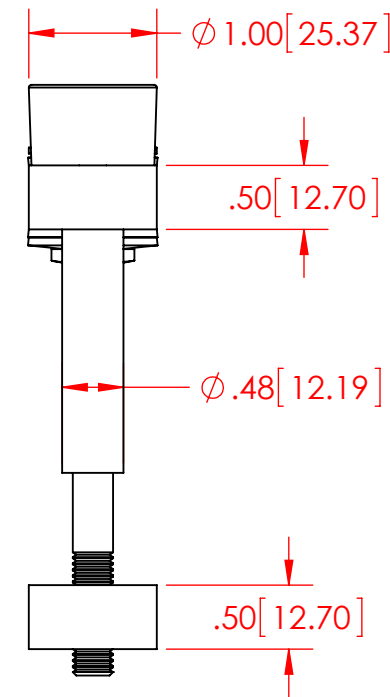
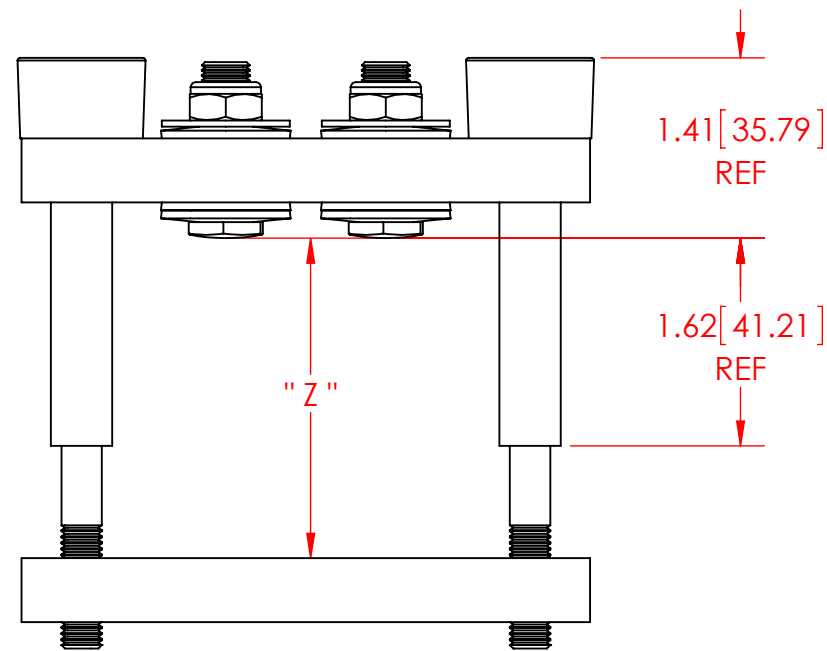
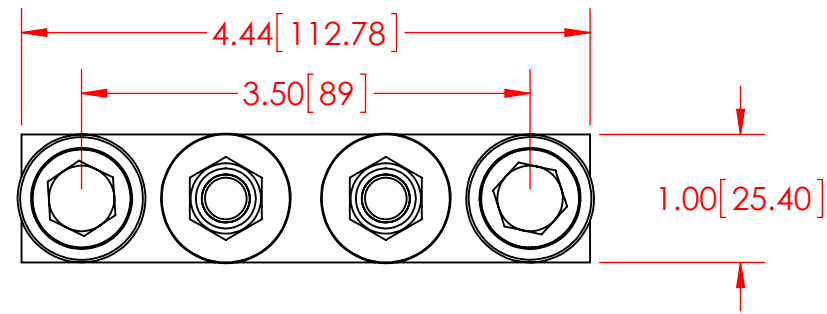

Notes:
1. DIMENSIONS IN INCHES [MILLIMETERS].

Dwg no.	IC89C15J	NAME	DATE	 1230 Old Innes Road, Unit 411-412 Ottawa, ON Canada K1B-3V3 Tel: (613) 744-3670 Fax: (613) 744-8452 engineering@iconopower.com http://www.iconopower.com
Description	IC89C CLAMP	DRAWN	GUNVEET 13JUN11	
Revision		Designed		
Calibrated at	15kN	Checked	DEREK 26SEP11	UNLESS OTHERWISE SPECIFIED: TOLERANCES: .X +/- 0.1 .XX +/- 0.05 .XXX +/- 0.010 ANGULAR: +/- 0 deg 15 min
Z	2.50 - 2.75 [63.50 - 69.85]			
SCALE: 1:2	DO NOT SCALE DRAWING	SHEET 1 OF 1		PROPRIETARY AND CONFIDENTIAL THE INFORMATION CONTAINED IN THIS DRAWING IS THE SOLE PROPERTY OF ICONOPOWER LTD. ANY REPRODUCTION IN PART OR AS A WHOLE WITHOUT THE WRITTEN PERMISSION OF ICONOPOWER LTD. IS PROHIBITED. ICONOPOWER LTD. RESERVES THE RIGHT TO CHANGE THE DESIGN AT ANY TIME WITHOUT A NOTICE FOR PRODUCT IMPORVEMENT PURPOSES.