

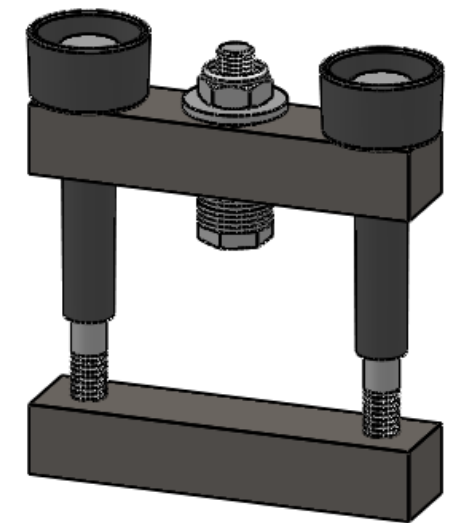

REVISION TABLE			
REV	DESCRIPTION	DRAWN	DATE
1			
2			

Item No.	Part Number	DESCRIPTION	QUANTITY
1	Bolt	M6 x 70 mm	2
2	Insulator	M6 x 40 mm	2

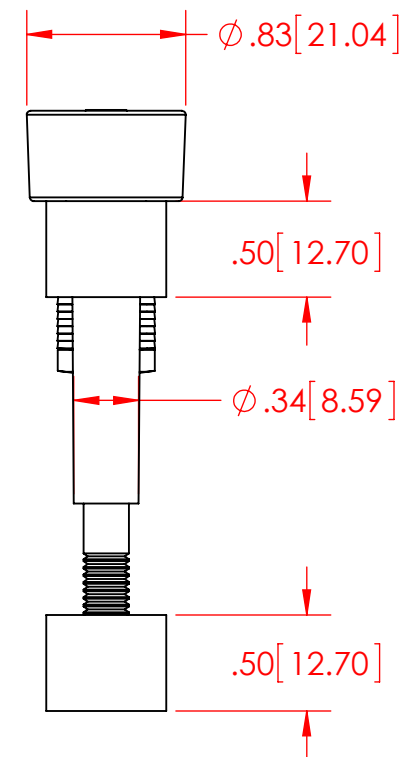
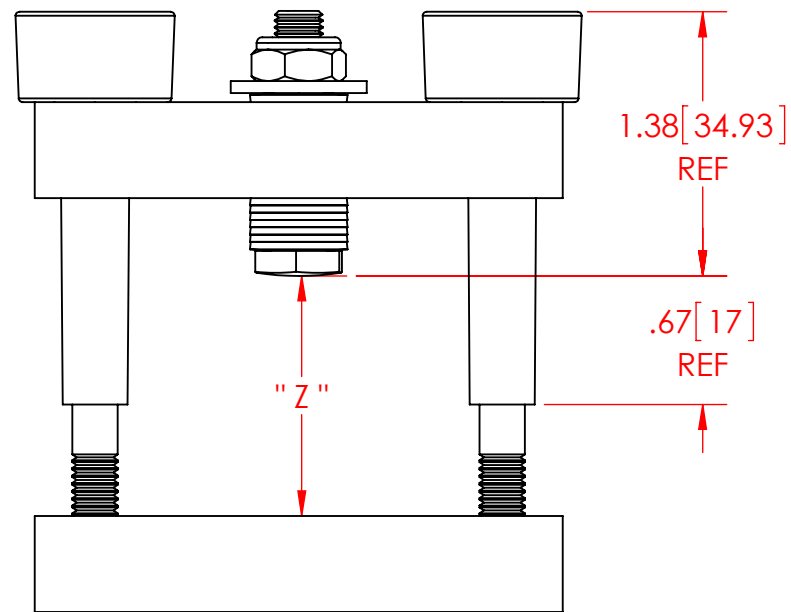
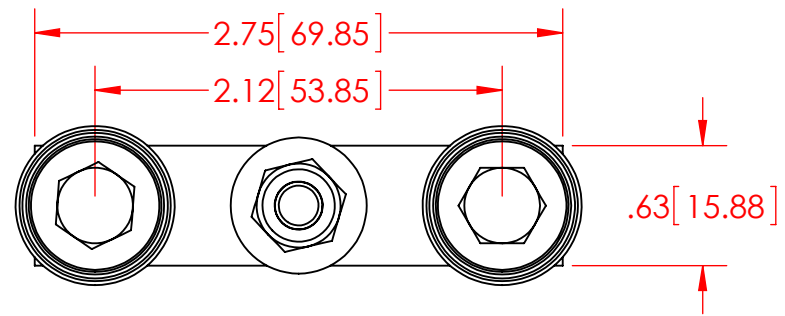

Notes:
1. DIMENSIONS IN INCHES [MILLIMETERS].

Dwg no.	IC54C9C	NAME	DATE	 1230 Old Innes Road, Unit 411-412 Ottawa, ON Canada K1B-3V3 Tel: (613) 744-3670 Fax: (613) 744-8452 engineering@iconopower.com http://www.iconopower.com
Description	IC54C CLAMP	DRAWN	GUNVEET 08APR11	
Revision		Designed		
Calibrated at	9kN	Checked	DEREK 26SEP11	
Z	1.00 - 1.25 [25.40 - 31.75]	UNLESS OTHERWISE SPECIFIED:		PROPRIETARY AND CONFIDENTIAL
SCALE: 1:1	DO NOT SCALE DRAWING	TOLERANCES: .X +/- 0.1 .XX +/- 0.05 .XXX +/- 0.010		THE INFORMATION CONTAINED IN THIS DRAWING IS THE SOLE PROPERTY OF ICONOPOWER LTD. ANY REPRODUCTION IN PART OR AS A WHOLE WITHOUT THE WRITTEN PERMISSION OF ICONOPOWER LTD. IS PROHIBITED. ICONOPOWER LTD. RESERVES THE RIGHT TO CHANGE THE DESIGN AT ANY TIME WITHOUT A NOTICE FOR PRODUCT IMPORVEMENT PURPOSES.
	SHEET 1 OF 1	ANGULAR: +/- 0 deg 15 min		