

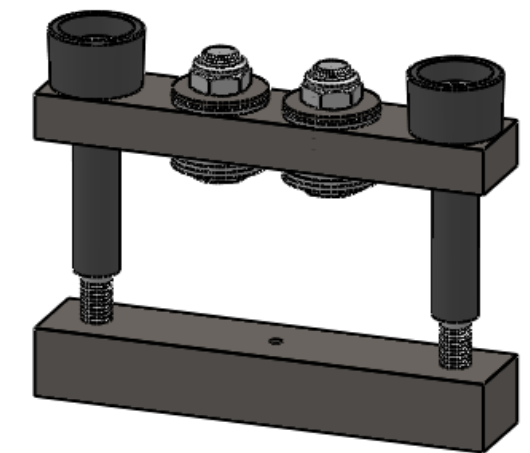

| REVISION TABLE | | | |
|----------------|-------------|-------|------|
| REV | DESCRIPTION | DRAWN | DATE |
| 1 | | | |
| 2 | | | |

| Item No. | Part Number | DESCRIPTION | QUANTITY |
|----------|-------------|-------------|----------|
| 1 | Bolt | M8 x 85 mm | 2 |
| 2 | Insulator | M8 x 52 mm | 2 |

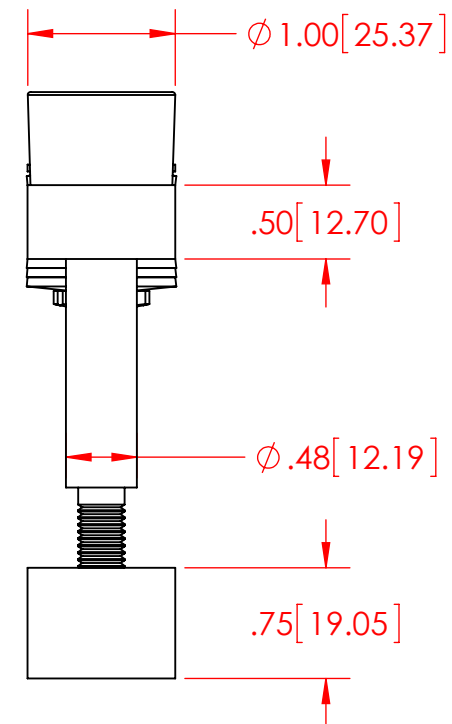
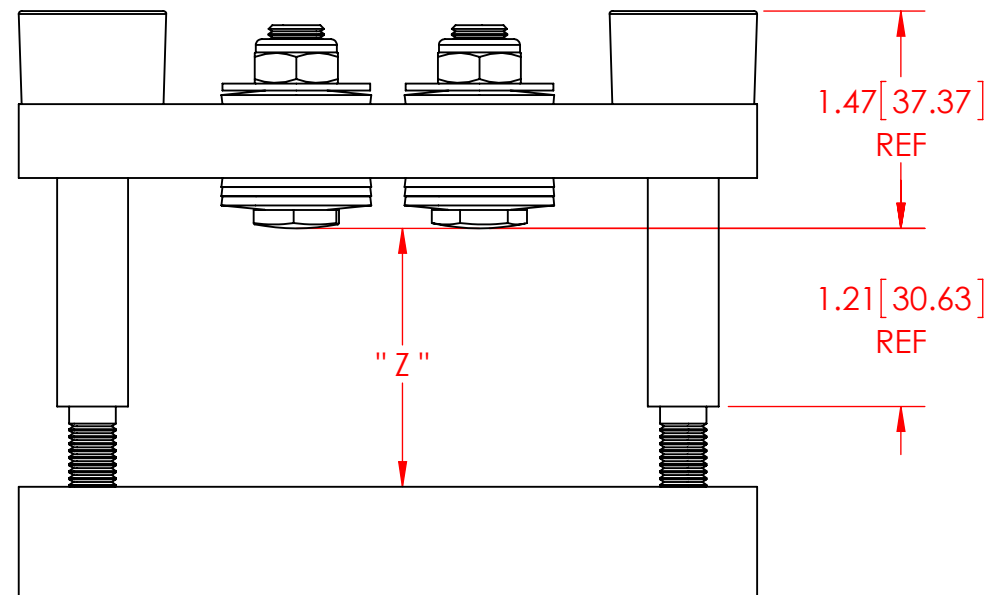
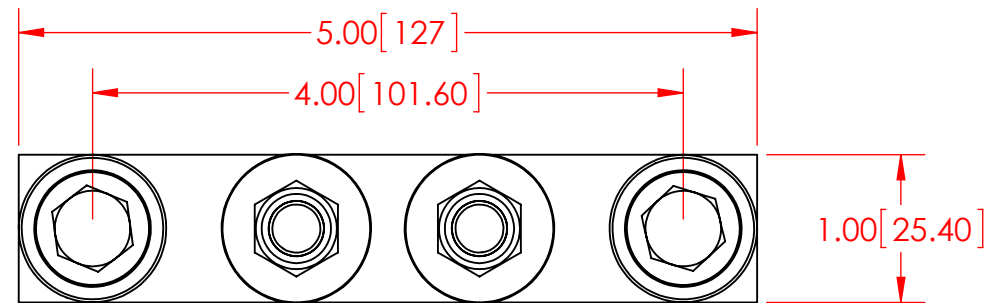

Notes:
1. DIMENSIONS IN INCHES [MILLIMETERS].

| | | | | |
|---------------|-----------------------------|--|-----------------|--|
| Dwg no. | IC102C22E | NAME | DATE |  1230 Old Innes Road, Unit 411-412 Ottawa, ON Canada K1B-3V3 Tel: (613) 744-3670 Fax: (613) 744-8452 engineering@iconopower.com http://www.iconopower.com |
| Description | IC102C CLAMP | DRAWN | GUNVEET 23JUN11 | |
| Revision | | Designed | | |
| Calibrated at | 22kN | Checked | DEREK 26SEP11 | |
| Z | 1.50 - 1.75 [38.10 - 44.45] | UNLESS OTHERWISE SPECIFIED: TOLERANCES: .X +/- 0.1 .XX +/- 0.05 .XXX +/- 0.010 ANGULAR: +/- 0 deg 15 min | | PROPRIETARY AND CONFIDENTIAL THE INFORMATION CONTAINED IN THIS DRAWING IS THE SOLE PROPERTY OF ICONOPOWER LTD. ANY REPRODUCTION IN PART OR AS A WHOLE WITHOUT THE WRITTEN PERMISSION OF ICONOPOWER LTD. IS PROHIBITED. ICONOPOWER LTD. RESERVES THE RIGHT TO CHANGE THE DESIGN AT ANY TIME WITHOUT A NOTICE FOR PRODUCT IMPROVEMENT PURPOSES. |
| SCALE: 1:2 | DO NOT SCALE DRAWING | SHEET 1 OF 1 | | |